



SI 1856
For technical personnel only!
1/2

SERVICE INFORMATION

WATER PUMPS FROM AUDI/SEAT/ŠKODA/VW

DANGER OF BREAKAGE: NOTE DURING FITTING!

Ref. no.*	Pierburg no.	Vehicles
06H121010A; 06H121026BA/CF/CQ/DD; 06J121026BG/P	7.07152.08.0	Many from Audi, Seat, Škoda, Volkswagen
06H 121 008 F; 06H 121 010/026 AN/BE; 06J 121 026 G/L	7.07152.35.0	
06H 121 026 AB/AF/AG/B/BE/BF/BP/CC/CD/CH/CM/CN/CP/DC/DN/N; 06J 121 026 A/F	7.07856.08.0	
06H 121 026 CM/DB	7.07856.37.0 ¹⁾	
06H 121 026 CM/DB	7.07856.40.0 ¹⁾	

¹⁾ Only available in the Asian market

With the water pumps listed above, there is a danger that the housing may break in the event of incorrect installation. The loss of cooling output may result in severe consequential damage, e.g. engine damage.

Causes for the damage symptoms include:

- Gaskets are contaminated with oil, e.g. due to oiling of the gasket or engine oil contamination in the surrounding area. This can cause the gasket to swell and the housing to break (Fig. 2 and 3).
- The sequence of the screw connection and the tightening torques have not been complied with.

Therefore, please always observe the assembly instructions enclosed.



Fig. 2: Breakage (damage pattern)



Fig. 3: Breakage (damage pattern)

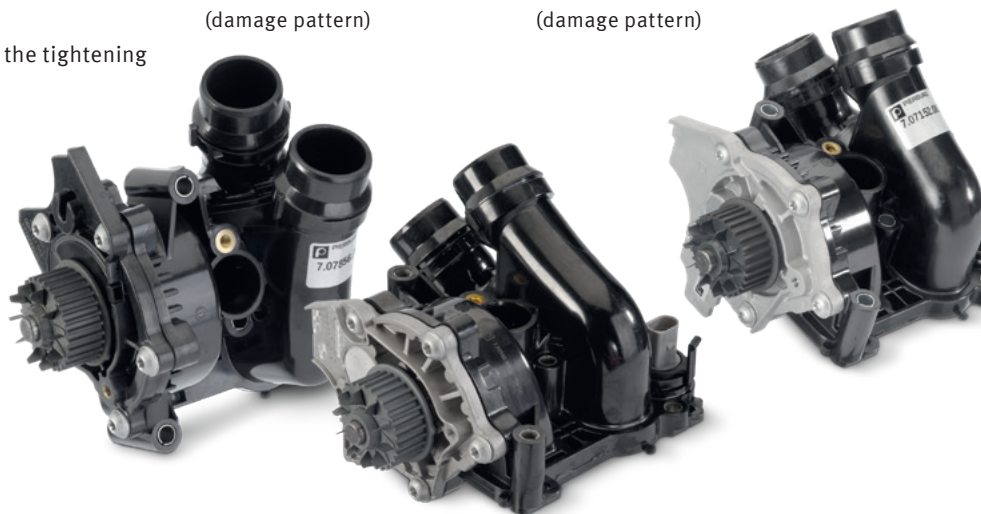

Fig. 1: View of product

All content including pictures and diagrams is subject to change. For assignment and replacement, refer to the current catalogues or systems based on TecAlliance.

* The reference numbers given are for comparison purposes only and must not be used on invoices to the consumer.



⚠ ATTENTION

Note during fitting:

- All gaskets of this water pump are exclusively designed for use with cooling liquid. They must never be oiled, e.g. with engine oil.
- The area around the installation location and the coolant agent must also be free from impurities.
- Contact with oil could cause the gaskets to swell in their groove, and the housing of the pump may break.
- Do not use additional sealant. The pump may develop leaks (Fig. 5).

👉 NOTE

Gaskets may be lubricated with cooling liquid to make mounting easier. Only use new sealing rings.

⚠ ATTENTION

- The sequence for tightening the bolts must be followed (Fig. 4): [A] – [B] – [C] – [D] – [E]
- Tightening torque: 9 Nm
- Risk of injury:
Only remove yellow protective cap* (Fig. 6) on the ventilation wings after installation.

👉 NOTE

Minor leakage of cooling liquid at the leakage hole is due to the design and does therefore not constitute reason for complaint. Depending on the version of the water pump, the temperature sensor** (Fig. 6) is either pre-assembled or included separately.

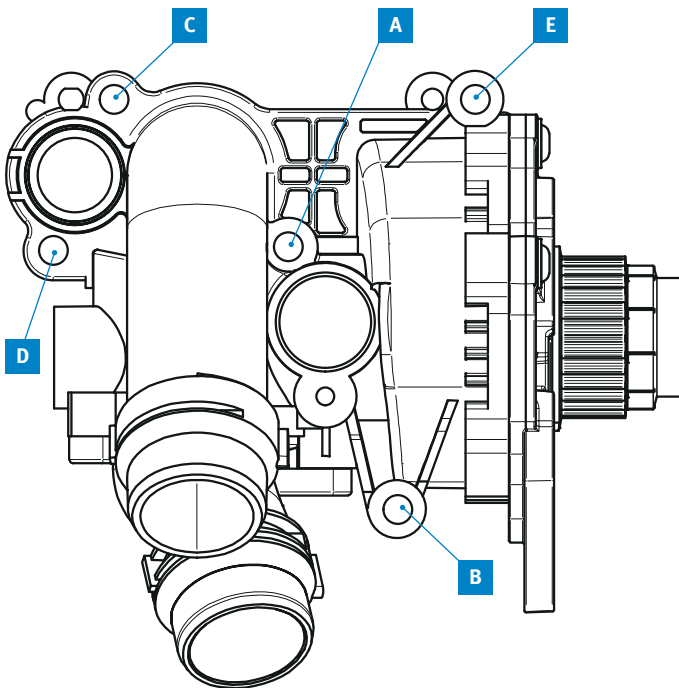

Fig. 4:
Sequence of the screw connection [A] – [B] – [C] – [D] – [E]



Fig. 5: Leakage due to additional sealant (damage symptoms)

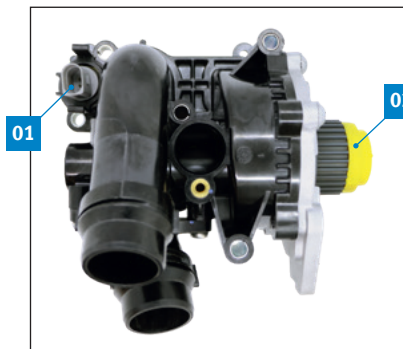

Fig. 6:
01 Temperature sensor*
02 Yellow protective cap**