



MEYLE[®]
Products



MEYLE No.

Reference No.

Tie rod end, right 016 020 0039/HD

414 460 01 05

Tie rod end, left 016 020 0040/HD

414 460 00 05

Tie rod end to fit Mercedes W414 (Vaneo)



as OE



Problem

- Intense strain and high surface pressure wears on the ball joint (head diameter 25mm)
- Premature wear

Effect

- Noise and play in the steering
- Impaired driving safety



Solution



- Increased diameter of the ball head of the tie rod end to 26 mm
- Use of extremely long-wearing plastic ball joint sockets (in aviation tried and tested material)

Advantage

Increase of load bearing capacity ensures a significant longer lifetime

as OE

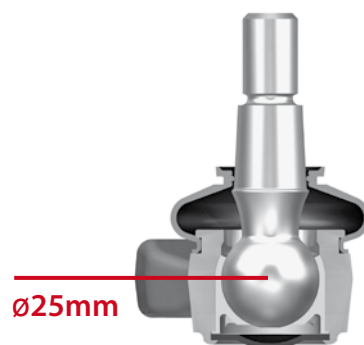

ø25mm

MEYLE-HD version

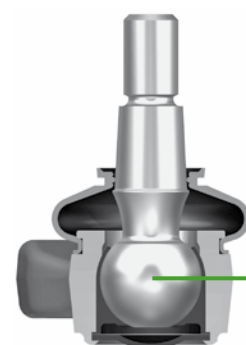

ø26mm